

← GO BACK

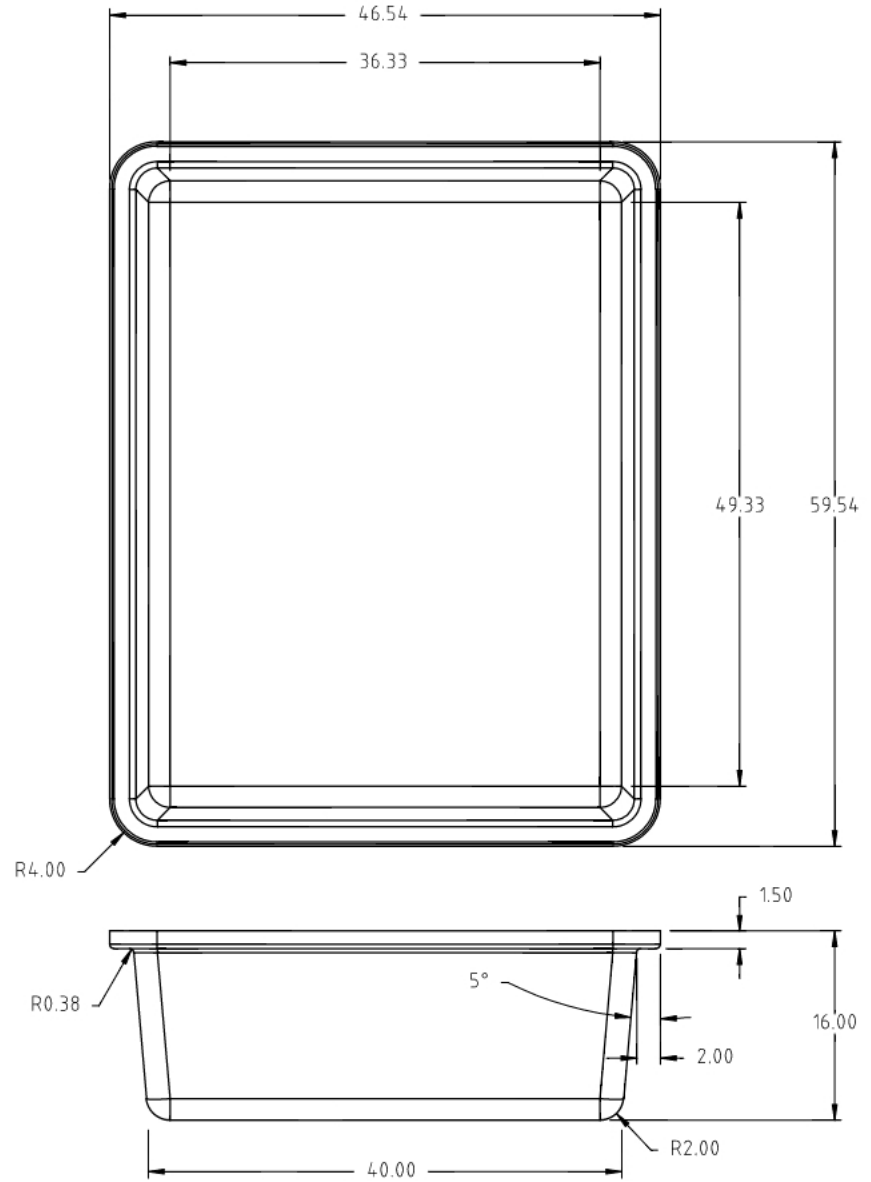
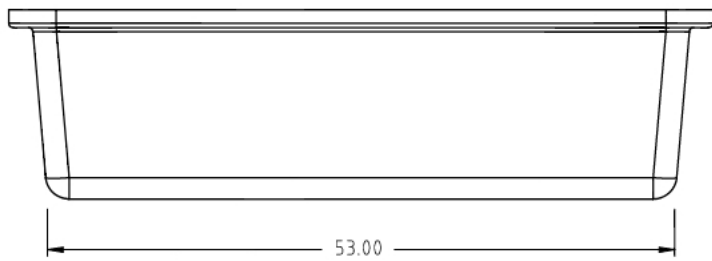
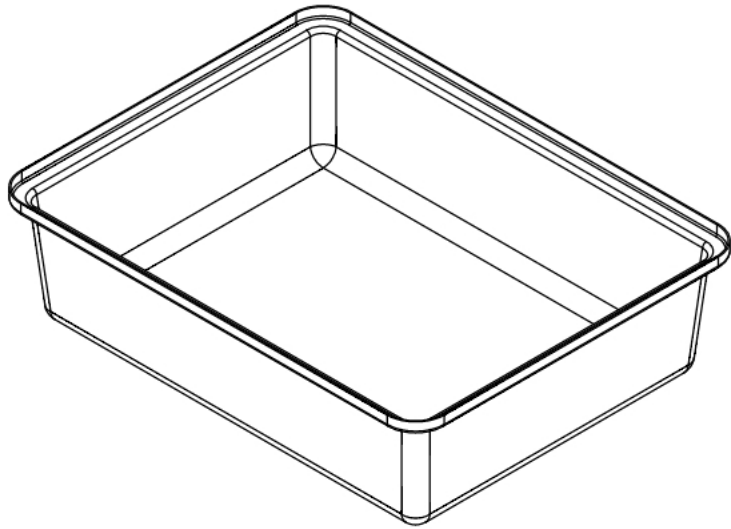

REV	DESCRIPTION	BY / DATE	CCN	DRAWN / DATE ADH 2/6/12	MATERIAL 10420 NATURAL
				APPRD. / DATE REH 2/6/12	
ALL DIMENSIONS ARE IN DECIMAL INCHES TOLERANCES UNLESS OTHERWISE SPECIFIED				SHOT WEIGHT: 71 LB.	NOTES: 1.) NOM. WALL 0.18"
POLYETHYLENE				SHIPPING WEIGHT: 35 LB.	
±1% @ 68° F				FINISH:	
METAL DECIMAL ± .125" FRACTION ± 1/4" ANGLE ± 1°				THIRD ANGLE PROJECTION ANSI 14.5M	

**CSI**  
ChemIndustrial Systems, Inc.  
PO Box 500, Cedarburg, WI 53012  
262-375-8570 • (Fax) 262-375-8559 • info@chemindustrial.com

DESCRIPTION 150 GALLON CONTAINMENT TANK	
SCALE N.S.	PART NO. <b>TOP150GAL-PE-RT</b>